



EXV-S Electrically Heated Vaporizing Regulator

Installation and Operation Instructions

**Read and Comply with the Enclosed Instructions
Before Installing or Operating**

**AURA Gas Controls
1.800.582.2565
www.AURACONTROLS.com**

Registered
ISO 9001

99060452-AU-H

DESCRIPTION OF PRODUCT

This single-stage pressure regulator is equipped with a heating element intended to vaporize a liquid sample and maintain it in the gaseous state for chromatographic analysis. Further, it provides a positive heat source to prevent freeze up of the regulator. This product is designed for use in explosive atmospheres. It is intended for above ground use and is moisture resistant. For more information, refer to the Section "Certifications and Compliances" in this manual.

USER RESPONSIBILITY

This equipment will perform in conformity with the description contained in this manual and accompanying labels and/or inserts when installed, operated, maintained, and repaired in accordance with the instructions provided. It is the responsibility of the user to determine the suitability of this product for the gas service and application. It is also the responsibility of the user to install this product in accordance with National Electrical Codes and any local ordinances.

This equipment must be checked periodically. Improperly working equipment should not be used. Parts that are broken, missing, worn, or distorted should be replaced immediately. This equipment, or any of its parts, should not be altered without prior written approval by AURA. The user of this equipment shall have the sole responsibility for any malfunction that results from improper use, faulty maintenance, damage, improper repair, or alteration by anyone other than AURA or a service facility designated by AURA.

Service to this product should only be performed by AURA or an authorized AURA agent. Requests for service may be made through AURA CUSTOMER SERVICE.

- PHONE: 1-800-582-2565
- FAX: 1-757-422-3125
- E-MAIL: info@auracontrols.com

AURA accepts no responsibility for damage or injury if this product is modified in any way.

AURA assumes/accepts no liability or responsibility for damage to individuals or equipment that may occur when using this product.

CUSTOMER ASSISTANCE

In the event of equipment failure, call the AURA Customer Assistance Line:

1-800-582-2565 FAX: 1-757-422-3125 E-mail: info@auracontrols.com.

Please be prepared to provide the model number and serial number of the equipment involved in addition to some details regarding its application. This would include inlet and outlet pressures, flow rate, environmental conditions, and gas service.

GENERAL SAFETY PRACTICES



Basic safety precautions must be followed to reduce the risk of fire, electrical shock, and injury.

- Connect the Vaporizing Regulator to the correct line voltage. A label on the product identifies what voltage it is wired for. *CONNECTION TO AN INCORRECT VOLTAGE CAN CAUSE SERIOUS DAMAGE TO THE PRODUCT AND WILL VOID ANY WARRANTY.*
- PRODUCT OPERATES AT HIGH TEMPERATURES. DO NOT TOUCH WHEN ON. ALLOW SUFFICIENT TIME TO COOL BEFORE HANDLING.
- Do not use in areas where large amounts of dust are present.
- If product appears damaged in any way, do not use and request service from AURA.
- Do not attempt to operate the Vaporizing Regulator with the electrical box cover off.
- Comply with precautions listed in C.G.A. Pamphlet P-1, Safe Handling of Compressed Gases in Containers.
- Never use an open flame when leak testing.
- Always open valves slowly when high-pressure gases are being used.
- Always leak-test any manifold or distribution pipeline before using.
- Always be sure that the gas in a pipeline is the correct gas for the intended use.

All gas distribution piping systems must meet the appropriate industrial standards for the intended service and must be thoroughly cleaned before using. For the United States, some applicable safety rules and precautions are listed below:

1. Local Ordinances
2. O.S.H.A. Standard 29 CFR
3. C.G.A. Pamphlet C-4, American National Standard Method of Marking Portable Compressed Gas Containers to Identify the Material Contained.
4. C.G.A. Pamphlet C-4.1, Equipment Cleaned for Oxygen Service.
5. C.G.A. Pamphlet G-4.4, Industrial Practices for Gaseous Oxygen Transmission and Distribution Piping Systems.
6. C.G.A. Pamphlet G-5, Hydrogen - Information on the Properties, Manufacture, Transportation, Storage, Handling, and Use of Hydrogen.
7. C.G.A. Pamphlet P-1, Safe handling of Compressed Gases in Containers.
8. C.G.A. Safety Bulletin SB-2, Oxygen Deficient Atmospheres.

C.G.A. Pamphlets can be obtained from:

Compressed Gas Association

1235 Jefferson Davis Highway

Arlington, VA 22202-3239

(703) 979-0900. Publications: (703) 979-4341. Fax: (703) 979-0134.

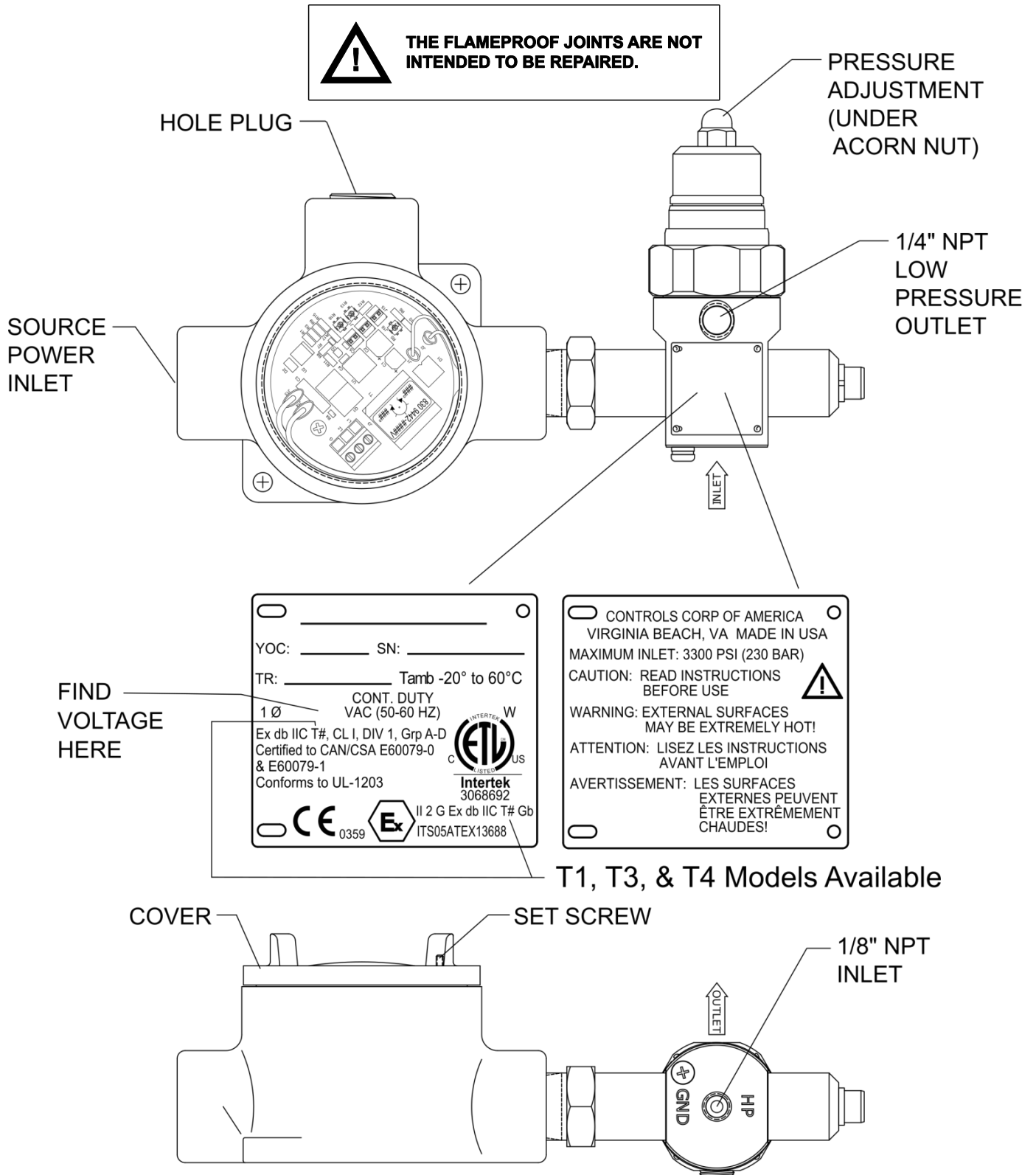

Figure 1 – Vaporizing Regulator Assembly

INSTALLATION OF ELECTRICAL CONNECTIONS

THE SELECTION, AND USE OF CONDUIT, FLEXIBLE TUBING OR ARMORED CABLE IS THE RESPONSIBILITY OF THE INSTALLER. PROPER CARE MUST BE TAKEN WHEN CONNECTING THE DEVICE TO ELECTRICAL POWER WHERE THE DEVICE WILL BE USED IN AN EXPLOSIVE ATMOSPHERE OR WITH COMBUSTIBLE GASES.

THE INSTALLER MUST FOLLOW ALL APPROPRIATE NATIONAL AND LOCAL ELECTRICAL CODES WHEN CONNECTING THIS DEVICE TO ELECTRICAL POWER. SPECIAL ATTENTION MUST BE PAID TO THE INSTALLATION OF THIS DEVICE WHEN USED IN EXPLOSIVE ATMOSPHERES.

Figure 2 – Source Power Connections

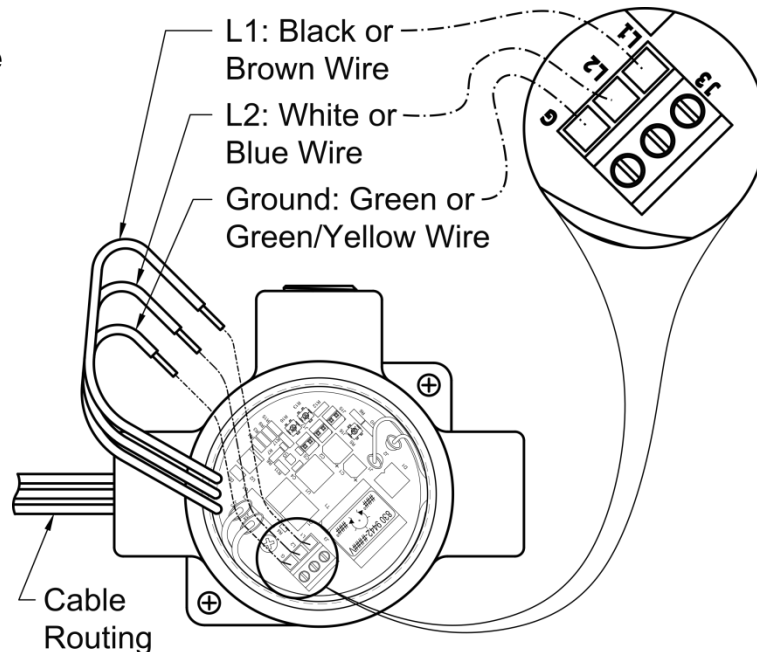

1. Remove the set screw from the cover on the electrical box and unscrew the cover.
2. Route the Electrical power into the enclosure through the threaded opening. Use the appropriate fitting to secure the conduit, etc. to the electrical enclosure. IN EXPLOSIVE ATMOSPHERES THE OPENING INTO THE ENCLOSURE MUST BE SEALED TO PREVENT A PATH FOR GAS TO TRAVEL. THE O-RING ATTACHED TO THE COVER IS NEEDED TO PREVENT MOISTURE FROM ENTERING THE ENCLOSURE. DO NOT REMOVE.

Note: Electrical connections to this product should be made with insulated, 18 AWG stranded copper wire with a minimum operating temperature of 75°C

3. Remove ¼" of the insulation from each of the wires.
4. Attach the power wires to the terminal block according to Figure 2.
5. Check that the temperature setting on the circuit board is correctly set. If not, refer to the "Temperature Adjustment" section of this manual.
6. Reattach the cover to the electrical enclosure securing it tightly.
7. Re-install the sets crew into the cover. This sets crew is intended to make the removal of the cover difficult without the use of tools. It is important that this screw be replaced.
8. Provision is made at the rear of the regulator for an external ground connection for locations where an external ground connection is required. The ground connection is clearly marked (GR), and a screw and washer is provided.

INSTALLATION OF GAS CONNECTIONS:

Note: BE SURE TO CONSIDER ALL FACTORS WHEN SELECTING MATERIALS FOR GAS CONNECTIONS.

For example, if you have both high pressure and corrosive service, select material that is suitable for both.

NPT connections require the use of PTFE tape on the threads to make a gas tight seal. On stainless steel connections, PTFE tape also helps to prevent the connections from galling together when tightening or loosening. Follow the rules below when using PTFE tape:

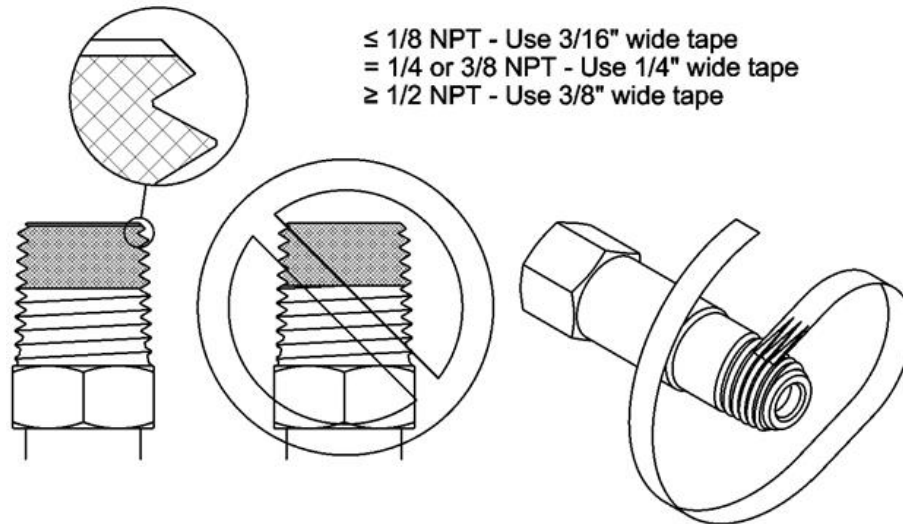

Taping procedure:

- 1 Do not use oil or grease on fittings, especially not on oxidizing gas service equipment.
2. Be sure that all fittings are secure and leak tight. PTFE tape should be used on pipe fittings, but avoid impinging on the gas stream. Before applying PTFE tape, inspect the NPT threads, and, if necessary, clean the fitting to remove any dirt or thread sealant that remains on the threads. Start the PTFE tape on the first thread leaving a slight section of the chamfer exposed as shown in the figure above. Make sure the tape does not overlap the end of the fitting. As the tape is wrapped in the direction of the thread spiral, pull tightly on the end of the tape so that the tape conforms to the threads. Apply at least 2 but no more than 3 layers of tape to the threads. Cut off excess tape, and press the end firmly into the threads.

PRESSURE ADJUSTMENT

The Vaporizing Regulator's delivery pressure is set at the factory. If the delivery pressure needs to be adjusted, follow the directions below.

1. The pressure adjustment is made from the top of the regulator bonnet.
2. Locate and remove the acorn nut at the top of the bonnet.
3. Using a 3/16" Allen wrench inserted into the set screw beneath the acorn nut, turn the set screw to vary the outlet pressure of the regulator. Turning the set screw clockwise will increase the pressure setting, and counter clockwise will reduce the pressure setting.
4. When the pressure is adjusted to the desired level, replace the acorn nut and secure in place.



NEVER EXCEED THE OUTLET PRESSURE RATING OF THE REGULATOR.

TEMPERATURE ADJUSTMENT

The Vaporizing Regulator operates over a specific temperature range. This range is determined by the part number. To gain access to the adjustment thermostat, the cover on the electrical enclosure must be removed.



REGULATOR SURFACES ARE EXTREMELY HOT WHEN OPERATING. ALLOW SUFFICIENT COOLING TIME AFTER REMOVING POWER BEFORE HANDLING.

1. TURN ELECTRICAL POWER OFF BEFORE OPENING THE COVER TO THE ELECTRICAL ENCLOSURE.
2. Remove the set screw from the cover of the electrical box, and unscrew the cover.
3. Using the thermostat adjusting tool provided with the regulator, adjust the thermostat. This tool must be used to prevent damage to the thermostat. Refer to Figure 4 for thermostat location. Note that fully counterclockwise (CCW) is the lowest setting in the range. Fully clockwise (CW) is the highest temperature in the range.
4. The temperature range for the Vaporizing Regulator is listed on the label affixed to the top of the circuit board inside the electrical enclosure. The temperature range listed on the label is body temperature. Actual gas temperatures will be dependent on the flow rate of the gas passing through the regulator, ambient temperature, and the temperature of the gas entering the vaporizing regulator.
5. Once thermostat is set, securely tighten the cover onto the electrical enclosure.
6. Re-install the setscrew into the cover. This setscrew is intended to make the removal of the cover difficult without the use of tools. It is important that this screw be replaced.
7. Restore Electrical Power.

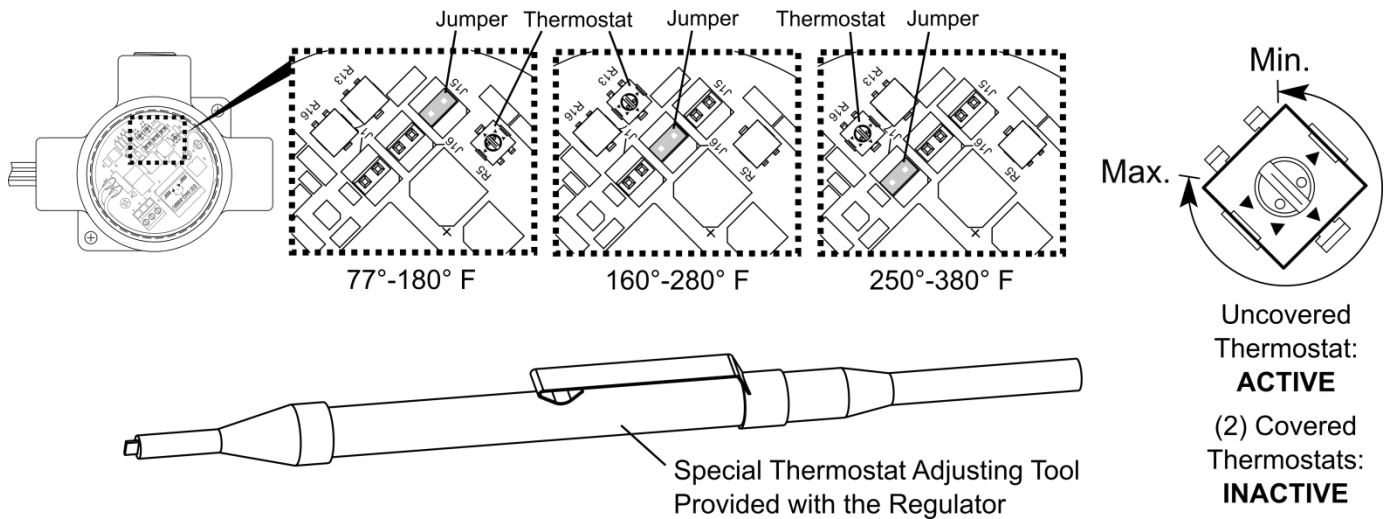

Figure 4 – Thermostat Location

TROUBLESHOOTING

Symptom	Possible Cause	Possible Solution
Regulator not heating	<ul style="list-style-type: none"> ▪ No Power to the Regulator ▪ Heater Element bad 	<ul style="list-style-type: none"> ▪ Check power connection at source. ▪ Check that wires are properly attached to the terminal block. ▪ Replace
No flow or restricted flow from regulator	<ul style="list-style-type: none"> ▪ Inlet plugged with debris 	<ul style="list-style-type: none"> ▪ Disconnect inlet gas source from regulator and clean inlet to regulator if plugged. ▪ Replace capsule inside regulator
Regulator Overheating	<ul style="list-style-type: none"> ▪ Bad Control Circuit board 	<ul style="list-style-type: none"> ▪ Replace
Regulator not heating gas sufficiently	<ul style="list-style-type: none"> ▪ Thermostat needs to be adjusted ▪ Ambient temperature & Gas inlet temperature too low ▪ Vaporizing Regulator chosen has too low a temperature range or wattage 	<ul style="list-style-type: none"> ▪ Adjust thermostat setting ▪ Using higher wattage Vaporizing Regulator ▪ Change Regulator to different heat range or wattage.

SERVICE

A Unit that is not functioning properly should not be used and should be returned to AURA for service. A Return Material Authorization (RMA) number must be issued for any product returned to AURA for service. Please contact a Customer Service Representative at 1-800-582-2565 to receive this number. You will be asked to provide:

1. Model Number
2. Gas Service
3. Inlet pressure and type of gas supply
4. Outlet pressure
5. Approximate gas usage

When shipping product back to AURA for repair, the following steps should be followed:

1. Package the product sufficiently to prevent damage. If possible return product in its original packing.
2. Include RMA number on the outside of the carton.
3. Ship prepaid.
4. Include a written description of the problem you encountered with the product inside the package.
5. Include a statement of the gas service the product was used in.
6. Purge all equipment before shipping to protect the transporter and service personnel. Purging is especially important if the equipment has been in hazardous or corrosive gas service.

CERTIFICATIONS AND COMPLIANCES

Tamb -20°C to 60°C

Ex db IIC T1, CL I, DIV 1, Grp A-D
Conforms to CAN/CSA E60079-0
& E60079-1
Conforms to UL-1203



T1 Rated model.



Tamb -20°C to 60°C

Ex db IIC T3, CL I, DIV 1, Grp A-D
Conforms to CAN/CSA E60079-0
& E60079-1
Conforms to UL-1203



T3 Rated model.



Tamb -20°C to 60°C

Ex db IIC T4, CL I, DIV 1, Grp A-D
Conforms to CAN/CSA E60079-0
& E60079-1
Conforms to UL-1203



T4 Rated model.









DECLARATION OF CONFORMITY

Description: EXV Series - Electrically Heated Vaporizing Regulators

Manufactured By: Aura Gas Controls

This Equipment Complies with the following:

<p style="text-align: center;">Tamb -20°C to 60°C</p> <p>Ex db IIC T1, CL I, DIV 1, Grp A-D Conforms to CAN/CSA E60079-0 & E60079-1 Conforms to UL-1203</p>  <p style="text-align: center;">Intertek 3068692</p> <p style="text-align: center;"><i>T1 Rated Model</i></p> <p>CE 2903  II 2 G Ex db IIC T1 Gb IECEX ETL 20.0042 ITS05ATEX13688</p>	<p style="text-align: center;">Tamb -20°C to 60°C</p> <p>Ex db IIC T3, CL I, DIV 1, Grp A-D Conforms to CAN/CSA E60079-0 & E60079-1 Conforms to UL-1203</p>  <p style="text-align: center;">Intertek 3068692</p> <p style="text-align: center;"><i>T3 Rated Model</i></p> <p>CE 2903  II 2 G Ex db IIC T3 Gb IECEX ETL 20.0042 ITS05ATEX13688</p>
<p style="text-align: center;">Tamb -20°C to 60°C</p> <p>Ex db IIC T4, CL I, DIV 1, Grp A-D Conforms to CAN/CSA E60079-0 & E60079-1 Conforms to UL-1203</p>  <p style="text-align: center;">Intertek 3068692</p> <p style="text-align: center;"><i>T4 Rated Model</i></p> <p>CE 2903  II 2 G Ex db IIC T4 Gb IECEX ETL 20.0042 ITS05ATEX13688</p>	

Notified Body:

Intertek Italia S.p.A. Via Miglioli, 2/A – 20063 Cernusco sul Naviglio, Milano - Italy

Standards:

- Explosion-Proof and Dust-Ignition-Proof Electrical Equipment for Use in Hazardous (Classified) Locations [UL 1203:2023 Ed.6+R:05Oct2023]
- Electric Heaters for Use in Hazardous (Classified) Locations [UL 823:2006 Ed.9+R:22Apr2016]
- Industrial Control Equipment>Valid without technical revision: 30Mar2020< [UL 508:1999 Ed.17+R:16Oct2013]
- Industrial Control Equipment{Non-Industrial Control Panels and Assemblies} [CSA C22.2#14:2018 Ed. 13]
- Explosive Atmospheres - Part 0: Equipment - General Requirements [CSA C22.2#60079-0:2019 Ed.4]
- Explosive Atmospheres - Part 1: Equipment Protection by Flameproof Enclosures "d" (R2021) [CSA C22.2#60079-1:2016 Ed.3]

Quality Manager



Warranties are extended only with respect to the purchase of PRODUCTS directly from AURA or its authorized DISTRIBUTOR as new goods and are extended to the first Buyer thereof other than for the purpose of resale.

For the life of the PRODUCTS to the first Buyer the PRODUCTS are warranted to be free from functional defects in materials and workmanship and to conform to the description of this equipment contained in its manual and any accompanying labels and/or inserts, provided that the same is properly operated under conditions of normal use and that regular periodic maintenance and service is performed or replacements made in accordance with the instructions provided. All electrical components in PRODUCTS are warranted to be free from functional defects in material and workmanship for only twelve (12) months from the date of purchase.

AURA's sole and exclusive obligation and DISTRIBUTOR's sole and exclusive remedy under the above warranties is limited to repairing or replacing, free of charge, at AURA's option, the PRODUCTS, which are reported to DISTRIBUTOR from whom purchased, and which if so advised, is returned with a statement of the observed deficiency, to AURA or its designated service facility during normal business hours, transportation charges prepaid, and which, upon examination, is found not to comply with the above warranties. Return trip transportation charges for the equipment shall be paid by DISTRIBUTOR.

There are no express or implied warranties which extend beyond the warranties hereinabove set forth. AURA makes no warranty of merchantability or fitness for a particular purpose with respect to the goods or parts thereof.

This Warranty does not cover any damage to PRODUCTS that result from improper installation, accident, abuse, misuse, natural disaster, insufficient or excessive electrical supply, abnormal mechanical or environmental conditions, debris or particles in the gas or liquid source of supply, corrosion, or any unauthorized disassembly, repair, or modification.

The foregoing warranties shall not apply if the PRODUCTS have been 1) repaired other than by AURA or its designated service facility, 2) not in accordance with written instructions provided by AURA, or 3) altered by anyone other than AURA.

AURA SHALL NOT BE OTHERWISE LIABLE FOR ANY DAMAGES INCLUDING BUT NOT LIMITED TO INCIDENTAL DAMAGES, CONSEQUENTIAL DAMAGES, OR SPECIAL DAMAGES, WHETHER SUCH DAMAGES RESULT FROM NEGLIGENCE, BREACH OF WARRANTY OR OTHERWISE.



AURA Gas Controls
1.800.582.2565
www.AURACONTROLS.com

99060452-AU-H